

**Greenway Technical Committee Staff
Meeting Notes
Tuesday, December 8, 2009
Grand Forks Park District Office - 1210 7th Ave. S. Grand Forks, ND
10:30 am- Noon**

Lonny Winrich, Chair
Dave Aker, EGF Parks & Rec
Melanie Parvey, City of GF

Steve Mullally, GF Park District
Kim Greendahl, City of GF

Guests: Mike Coleman, GF Lions' Club
Katie Osborne, Urban Development & Near Northside Neighbors (NNN)

Old Business

- a. **Cross country ski & snowmobile routes in Grand Forks:** The signs have been installed along the route. If there are problems with snowmobiles in unauthorized areas they should be reported to the police department for action.

II. New Business

a. **Project request forms**

- i. **Lions request for temporary storage:** The Lions' Clubs would like to install a temporary storage building at the Lincoln Drive Park boat ramp to store ten or twelve displays used for Christmas in the Park. This storage unit would be at the site year round but could be moved if needed during high water events. The displays are currently being stored at a remote site and are getting damaged during transport and the storage space is also getting too small for their needs.

The covenants on some of the properties in Lincoln Drive Park do not allow for the construction of permanent structures. GF Park District requested a permanent structure near that same area but the request was denied by the North Dakota Department of Emergency Services office. The committee is concerned about the aesthetics of a temporary trailer in the park, the intent of the Greenway for recreation and a floodplain and the potential for more requests for similar facilities.

The Park District is willing to work with the Lions' to find a space to store a pull behind trailer off site when Christmas in the Park is not in operation. The pump station at the park entrance may also be an option. Melanie will look into this. Mike will talk to the Lions' about a trailer on wheels to store at Lincoln Park golf course.

Solar lighting at 7th Avenue north – This was an idea that came out of the north end neighborhood meetings and charettes. The Near Northside Neighborhood (NNN) group has some dollars available to try addressing concerns about safety. They would like to consider solar lighting in the Greenway as a way to address this concern. The NNN are asking for the consideration of installing two lights at the 7th Avenue North entrance, with a match from the city, as a pilot project. There is also an interest for lights at the 2nd Avenue North entrance. This project would have to be taken to the Public Service Safety Committee for approval.

Lighting was included in the original plan but was dropped in Grand Forks. East Grand Forks has a few solar lights on the path along the Red Lake River and on Louis Murray Bridge for the boat ramp. Kim will contact EGF and light

manufacturers for more details about how well they work in our climate and product costs. Lonny brought information on self contained solar lights that he found on the internet

- ii. **Boat dock request:** GF City staff met to discuss the possibility of purchasing and installing a boat dock this summer. It was decided to pursue funding for a dock through the North Dakota Game & Fish Department. The funding requires a 25% match from the local community. This will be an informational item at the January 5 Public Service Safety Committee meeting. Melanie is working on a letter of application for the deadline of January 1.
- iii. **Disc golf tee pads and expansion:** Kim has sent a letter to the applicant informing him that the request for expansion has been denied based on the potential for a small dog park on the site and a concern that disc golf dominates the recreation in the park.
- b. **Pursuit of 502 (c) status:** The committee would like to be able to accept funds from outside sources like grants and donations but most times these grants require 501 (c) 3 status with the Internal Revenue Service. It was hoped that the Friends of the Greenway could serve as a conduit for funds or they could transfer their non-profit status to the Greenway Technical Committee but the Friends are in the process of disbanding and are not interested in transferring their status. Kim will begin the process of pursuing a non-profit status for the Greenway Technical Committee. The filing fees will be paid for either through the Greenway promotions fund. If the funds in the account insufficient the City of GF will find a way to fund the process.
- c. **Updating of Greenway Plan:** It has been almost ten years since the first Greenway Plan was assembled by Greenways Incorporated. Many of the projects included in the original plan have been installed in the Greenway but the recent project requests have demonstrated that it now is a good time to review and update the plan. This is a large item that could generate a lot of discussion so it might be a good idea to set aside an entire meeting to discuss this subject. Kim will work on assembling information about the previous plan and what has been done to date. If that information is available soon enough the February meeting can focus on updating the plan.
- d. **Greenway & Trail Users Advisory Group update:** The item on the agenda for tonight is winter events. The group will be discussing what activities are taking place and how they can help promote those activities and events.

III. Greenway Agency Updates

- a. **City of East Grand Forks:** EGF has applied to the Friends of the Greenway for funding for a playground in the campground but Dave has not heard back from them. Lonny will look into the application status. An application for funding was also submitted to the MN DNR for rerouting the path at LaFave Park so the lower path can be abandoned and turned over to the anglers who access the riverbank. The Council is not interested in funding the repairs if they do not receive outside funding. The City also applied for funds from the MN DNR to expand the size of the downtown boat ramp.
- b. **City of Grand Forks:** The idea of a community garden in the Greenway has surfaced again. Melanie will submit a project request form to begin the process for consideration.
- c. **GF Park District:** The dog park was vandalized by someone who drove a vehicle through the fence. So far there have been no arrests made in the case. The warming houses are now open Monday-Friday from 3:30 pm to 8:30 pm and 12:30 pm to 8:30 pm on weekends.
- d. **MN DNR:** No report

IV. Other

- a. **Winter Fest:** Plans are coming together for the event, scheduled for Saturday, February 13. The event starts with a pancake breakfast at the VFW in EGF and continues with the Grand Cities 100 snowmobile races, vintage snowmobile display, 5 & 10K Frozen Feat run/walk, wacky winter games, hands on activities for the kids and dog sled rides. There will be a soup tent at noon. Most events are free and open to everyone to enjoy (races require registration fees). Log on to www.grandforksgov.com/greenway for more information.
- b. **Friends of the Greenway:** The Friends have filed a letter with the state of Minnesota to announce their intent to dissolve the organization. They plan to give their remaining funds to the Community Foundation of GF EGF & Region. The group is in the process of writing the criteria for funding approval of applications to the Foundation for future projects.

V. **Next Greenway Technical Committee meeting: January 12, 2009 – 10:30 am at Grand Forks Park District, 1210 7th Avenue South**

Attachments: Solar light information from Solar Path
Greenway maps:
Community Green
Downtown Section – GF
Grand Forks Nature Center
Riverside Park
Greenway Soils
Riverside Amphitheater
Early Concept Plan
East Grand Forks Concept Plan

Submitted by: Kim Greendahl, Greenway Specialist, City of Grand Forks

Pavement

Street Names

Pavement

Traffic

Controlers

Signal

Xwalks

Plat

Sub Name

Lot Number

Block Number

Address

BLOCK

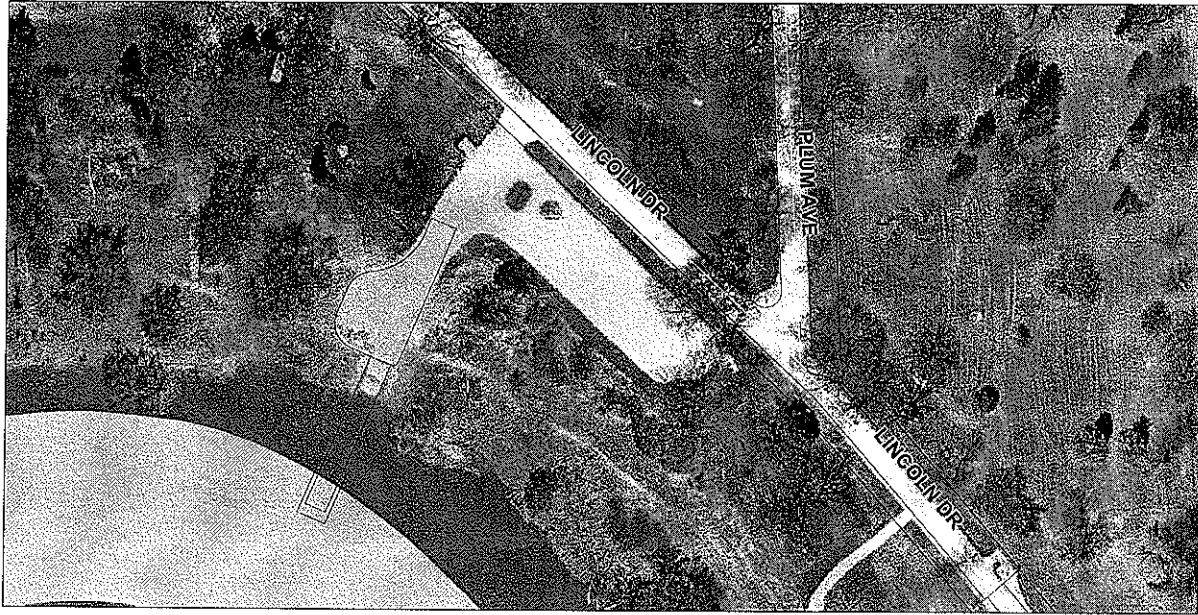

SCALE 1 : 2,148

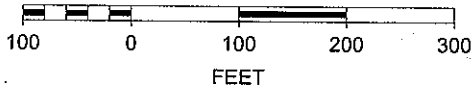

SolarPathTM
SUN SOLUTIONS

Where solar innovations come to light!TM



HighLightTM
series

ML 30

SolarPath brings you the most advanced in Solar powered street, road, path and area lighting. The HighLight Series, composed of top-of-the-line components, guarantees high performance and cost saving solutions - All powered by the sun!

www.solarpathusa.com

SolarPath Inc. 123 Town Square Pl. #333 Jersey City, NJ 07310 USA US: +1.888.333.5677 (7652) Intl.: +1.201.490.4499 contact@solarpathusa.com

SolarPathTM
SUN SOLUTIONS

Where solar innovations come to light!TM

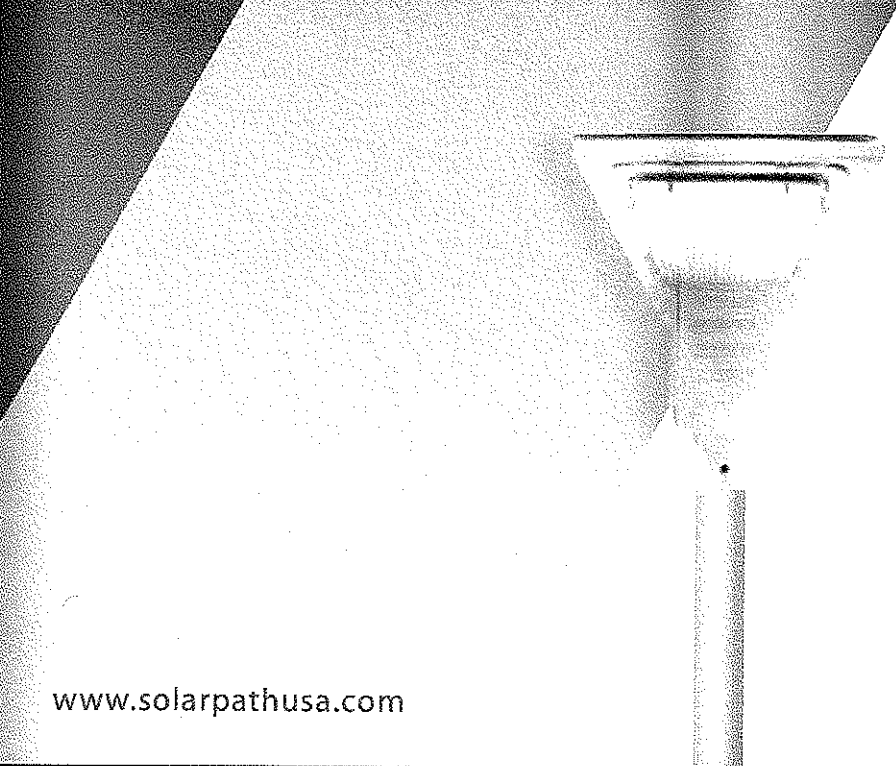

HighLightTM
series

ML 20

www.solarpathusa.com

SolarPath brings you the most advanced in Solar powered street, road, path and area lighting. The HighLight Series, composed of top-of-the-line components, guarantees high performance and cost saving solutions - All powered by the sun!

SolarPath Inc. 123 Town Square Pl. #333 Jersey City, NJ 07310 USA US: +1.888.333.SOLAR(7652) Intl.: +1.201.490.4499 contact@solarpathusa.com



ML-20

HighLight ML-20 is the most compact model of the HighLight ML family of products.

HighLight ML-20 is a versatile multipurpose fixture for small utility illumination applications.

Key features:

- Compact "all in one DIY design" for easy and safe self-installation
- Ultra-bright homogeneous LED light distribution
- Strong, weather-proof housing design
- Vandal resistant
- Recommended installation height of 13ft (4m)

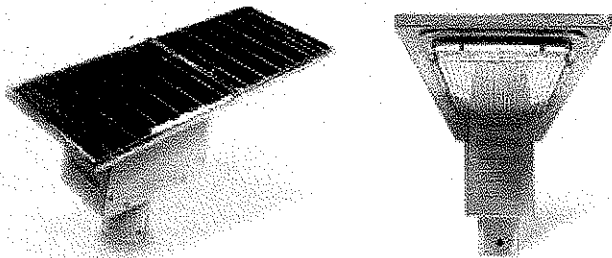
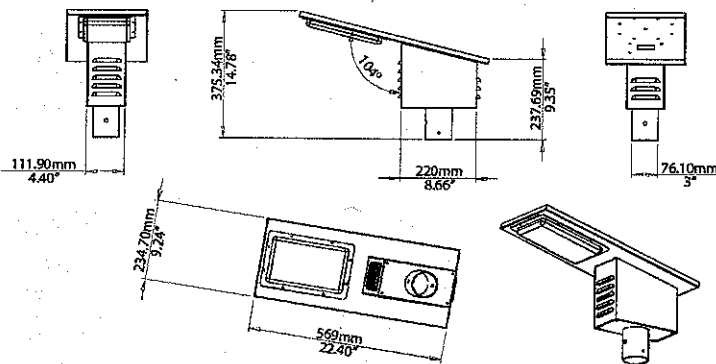

www.solarpathusa.com



Legal Clarification: All technical information and/or products listings and/or technical support, and/or any kind of graphics, illustrations and/or instructions and/or the names, trade names, trademarks, trade symbols, service marks, logos, icons and trade dress of SolarPath Inc or in connection to SolarPath Inc or any of its selling products, contained herein is in the exclusive ownership of SolarPath Inc and may not be alternated and/or used in any manner including but not limited to copy of some or all of the said material by users and/or viewers or any third party for that matter of this document and the website to which it is linked without the express prior written permission of SolarPath Inc. Furthermore, redistribution or any kind of commercial use or alternation or any kind of use other than downloading presented information in some or all contents of downloadable documents, and/or downloadable contents, is strictly prohibited without express written prior permission. All information set out herein is subject to changes as may occur from time to time. SolarPath Inc is not responsible for, and cannot guarantee and shall not be held liable for any information or the accuracy of such in websites that it does not manage.

Uses and Applications Guide	
Mid-size roads	—
Streets lighting	—
Parking lots	—
Boardwalks	●
Farms	●
Public parks	●
Private gardens	●
Access roads	●
Walking paths	●
Bus stations	●

ML-20 Technical specifications			
Lighting and Operation			
Lighting Technology	60/72 x Ultra-Bright LEDs White OR "Warm white"		
Brightness <small>(estimate measure for simulation purposes only. May vary)</small>	Equivalent to a 35w home-use, white light bulb		
On/Off operation	Automatic day/night detection, operates at dark/night only. Optional activation by sensors, push-button, computer, wireless receiver and the like		
Operation time	Up to 72 hours (per charge cycle)		
Energy Collection and Storage			
Solar panel type	Mono Crystalline Silicon, 14W		
Battery type	Deep Cycle AGM / Gel-Cell		
Voltage / Current	12VDC 12AH		
Materials			
Body	Stainless Steel and Aluminum		
Dimensions (Main body)	Length	Width	Height
	22.40"	8.26"	11.02"
Dimensions (Pole mount diameter)	Inner	Outer	
	69.80mm	76.10mm	
Unit weight	Net: 22lbs/10kg, packed: 27lbs/12.2kg		
Optional Features			
Enhanced brightness	Available option		
Wide angle light spread	N/A		
220V/110V AC Hybrid	Available option		
Wind turbine hybrid	Available option		
Winter mode	N/A		
Other			
Warranty period	2 Years fixture warranty (not including battery)		

Contact your local SolarPath Sun Solutions representative below:

The Greenway

Riverside Amphitheater • Grand Forks, ND

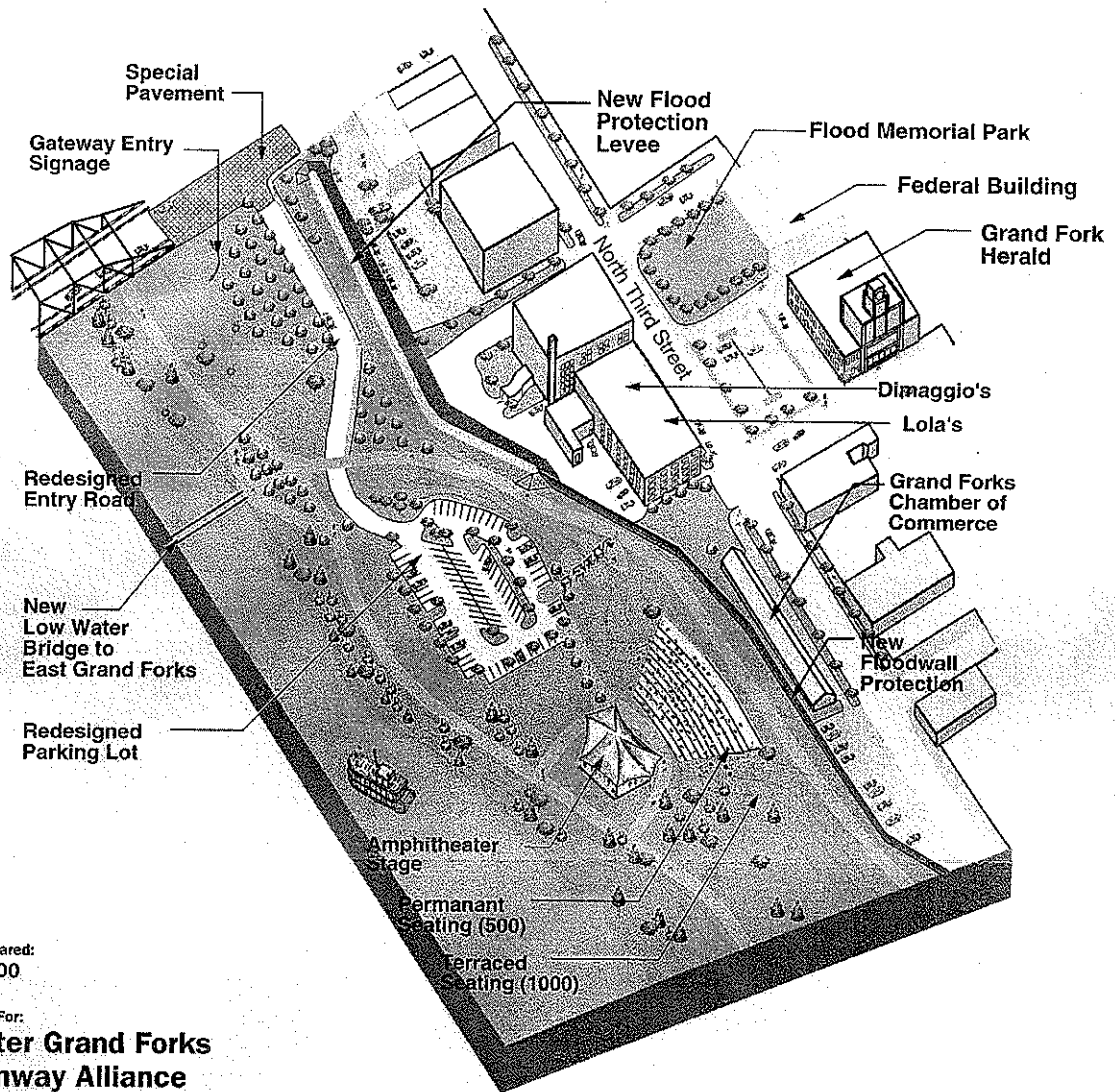

Date Prepared:
July 2000

Prepared For:
**Greater Grand Forks
Greenway Alliance**

Prepared By:

GREENWAYS
I.N.C.O.R.P.O.R.A.T.E.D.
Bicycle & Pedestrian Planning
Environmental Design
Landscape Architecture

The Greenway

Community Green • Grand Forks, ND

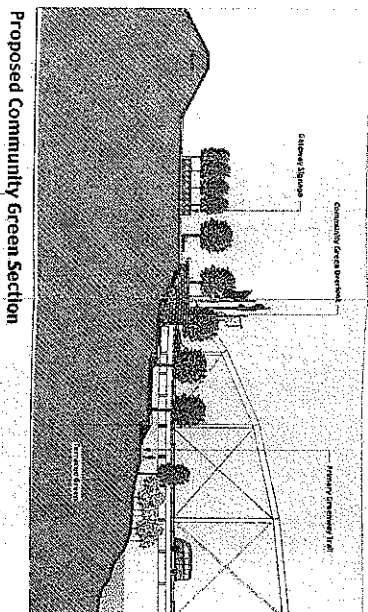
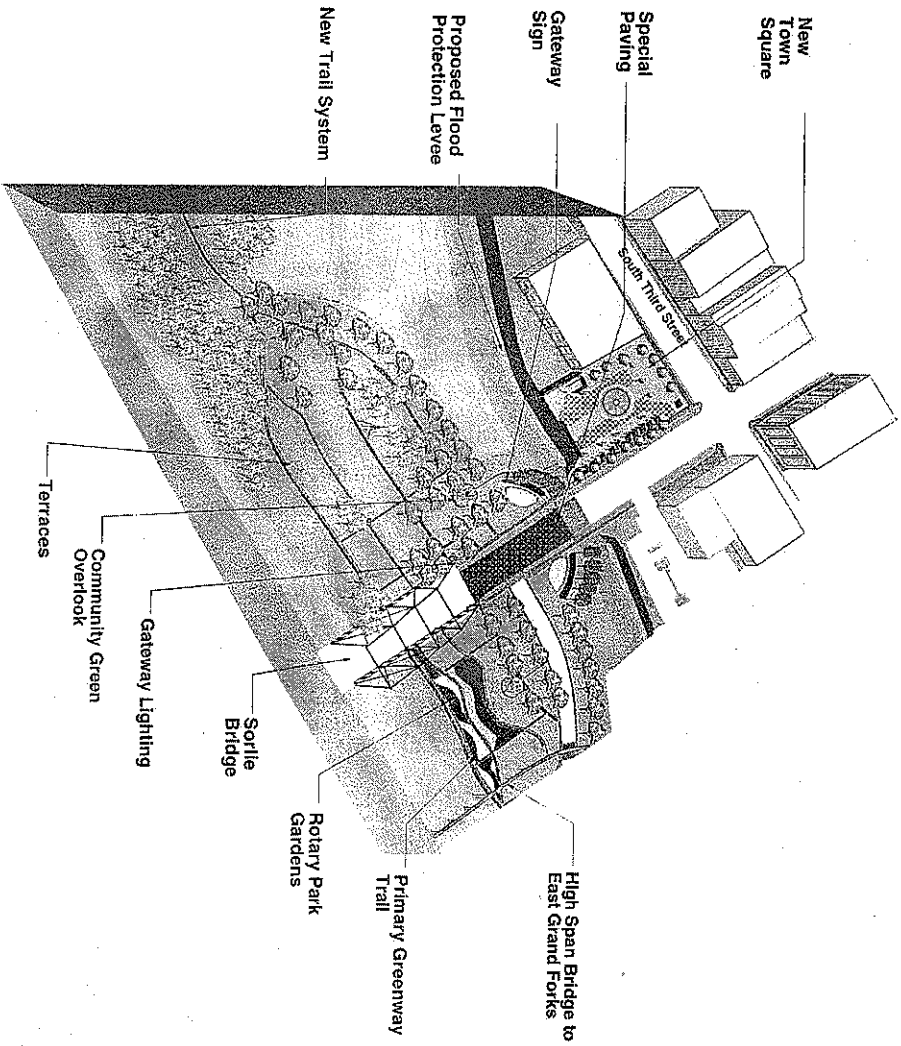

Proposed Community Green Section

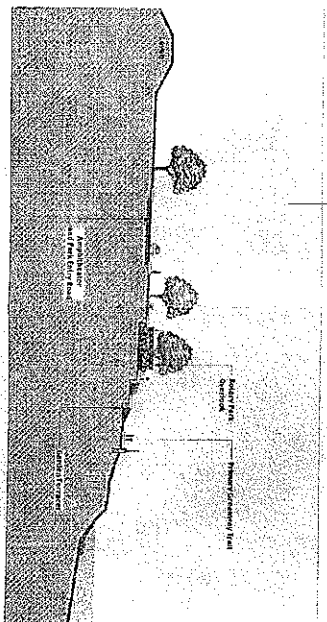

Proposed Rotary Park section

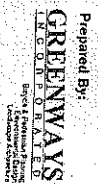

Date Printed:
July 2009
Prepared For:
Greater Grand Forks
Greenway Alliance

Prepared By:
GREENWAYS
A COMMUNITY

The Greenway

Grand Forks Nature Center
Grand Forks, ND

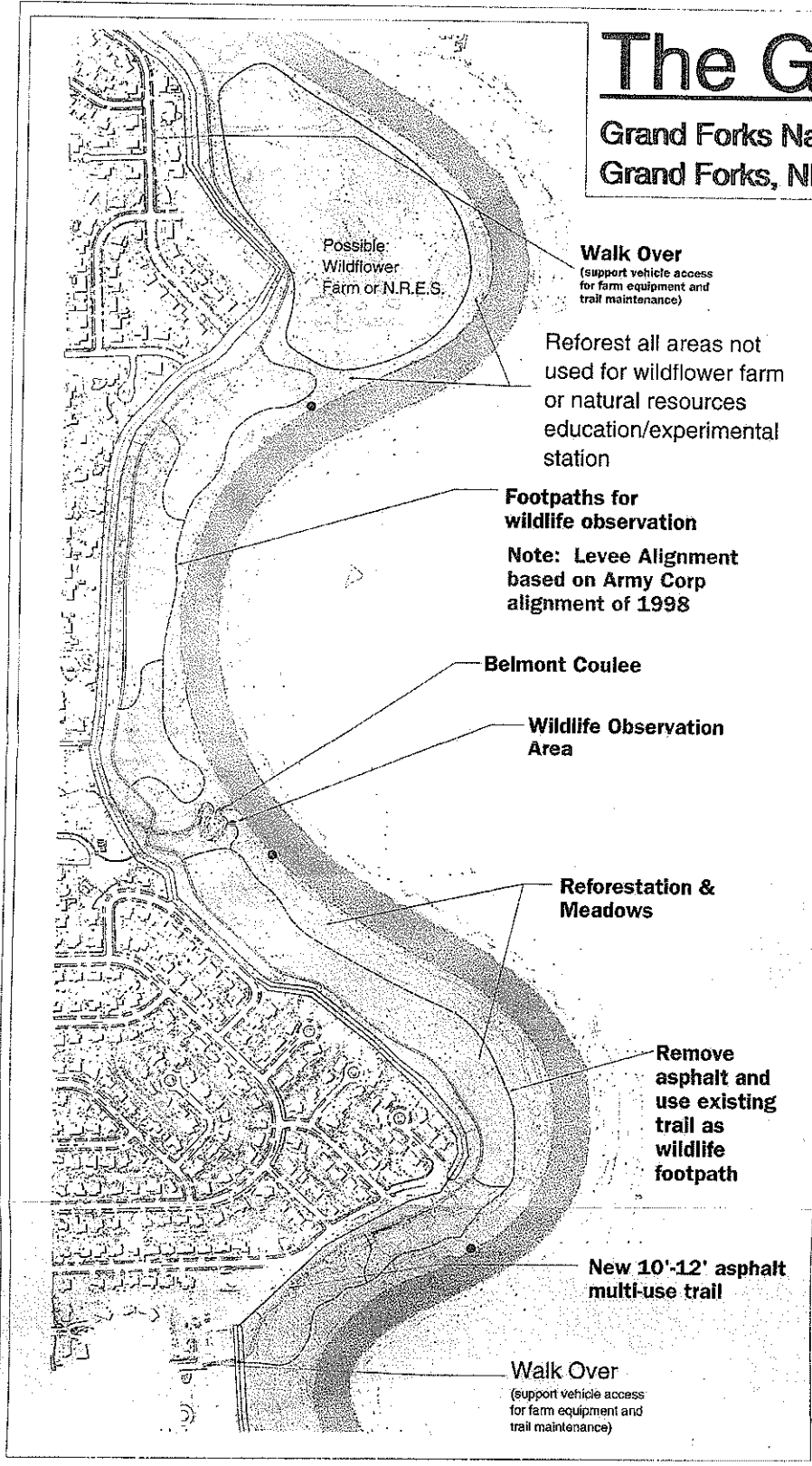

Possible Wildflower Farm or N.R.E.S.

Walk Over
(support vehicle access for farm equipment and trail maintenance)

Reforest all areas not used for wildflower farm or natural resources education/experimental station

Footpaths for wildlife observation

Note: Levee Alignment based on Army Corp alignment of 1998

Belmont Coulee

Wildlife Observation Area

Reforestation & Meadows

Remove asphalt and use existing trail as wildlife footpath

New 10'-12' asphalt multi-use trail

Walk Over
(support vehicle access for farm equipment and trail maintenance)

Date Prepared:
July, 2000

Prepared For:
Greater Grand Forks
Greenway Alliance

Prepared By:
GREENWAYS
A.S.C.P.C. 2002, L.L.C.



Legend

- EDGE & CUTTER
- EDGE OF ROADEXIDE
- GRAVEL, BIODEGRADABLE TRAIL
- ASPHALT & SURFING
- CONC. SURFING
- TRAIL
- WALL FENCE STANDING
- CONCRETE FENCE
- PIPE
- WOODEN
- FIELD LINE
- SHORELINE, STREAM
- SWAMP
- BUILDING WITH DECK
- STONE WALL
- SUBURBAN
- TRAIL OUTLINE
- NEAR CULTURE
- BURIED TREE OR BUSH
- WALL
- WATER SIGNAL
- POLE SIGNAL, LIGHT
- UTILITY POLE
- MANHOLE
- PIPE (NORMAL)
- CUTTER BLADE OR DIRT PILES
- RAILROAD
- CONCRETE
- WOODEN OBJECT
- POST
- ONE-WAY/VEHICLE CONTROL
- INDEX CONTROL
- INDEX APPROPRIATE
- INDEX APPROPRIATE
- INTERMEDIATE CONTROL
- INTERMEDIATE CONTROL
- INTERMEDIATE CONTROL
- SPOT ELEVATION
- SPOT ELEVATION
- SPOT ELEVATION
- SPOT ELEVATION

The Greenway

Grand Forks, ND • East Grand Forks, MN

East Grand Forks Soils Key

- 1006 Fluvaquents-Haploborolls complex, 0%-30% slopes
- 1323B LaDelle silt loam, 0%-3% slopes, occasionally flooded
- 1866 Colvin-Perelle complex
- 1871 Fargo silty clay, swales
- 1963 Bearden-Colvin complex
- 47 Colvin silty clay loam
- 422A Byglund silty clay loam, 0%-2% slopes
- 422B Byglund silty clay loam, 2%-6% slopes
- 67B Bearden silt loam, 2%-6% slopes
- 67A Bearden silt loam, 0%-2% slopes
- 667B Fairdale silt loam, 6%-20% slopes, occasionally flooded
- 694D2 Zell silt loam, 6%-20% slopes, eroded

Grand Forks Soils Key

- 10 Lamoure silty clay loam
- 126 Bearden silty clay loam
- 79B Zell LaDelle silt loams, 1%-6% slopes
- 79C Zell LaDelle silt loams, 1%-9% slopes
- 46 LaDelle silt loams, 0%-3% slopes
- 43B Cashel silty clay loam, 1%-6% slopes
- 43E Cashel silty clay loam, 6%-25% slopes
- 79D Zell LaDelle silt loams, 1%-15% slopes
- 25 Overly silty clay loam, 0%-3% slopes

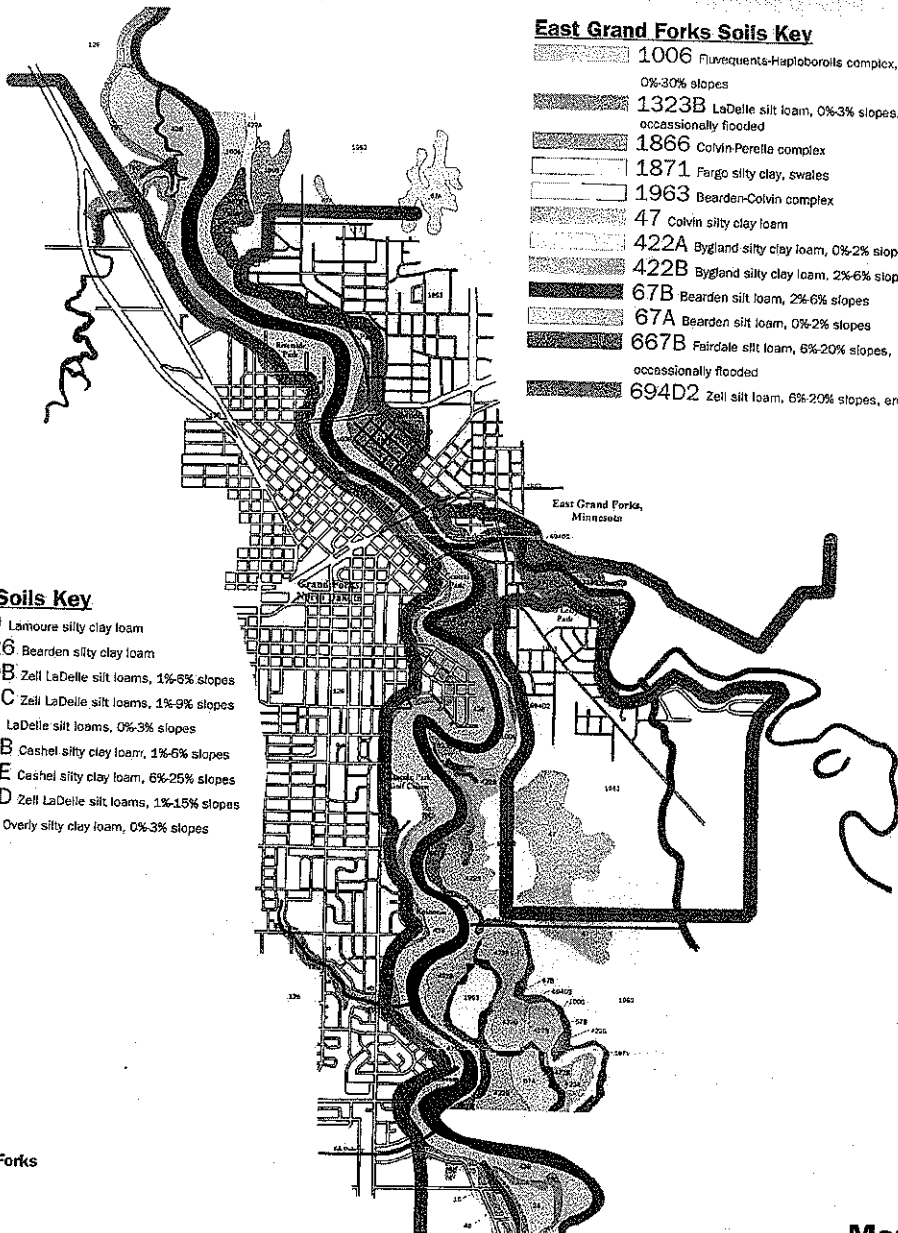

Date Prepared:
July 2000

Prepared For:
City of Grand Forks
City of East Grand Forks
Greenway Alliance

Prepared By:



Map 2
Soils Map

RED RIVER OF THE NORTH GREENWAY Conceptual Plan

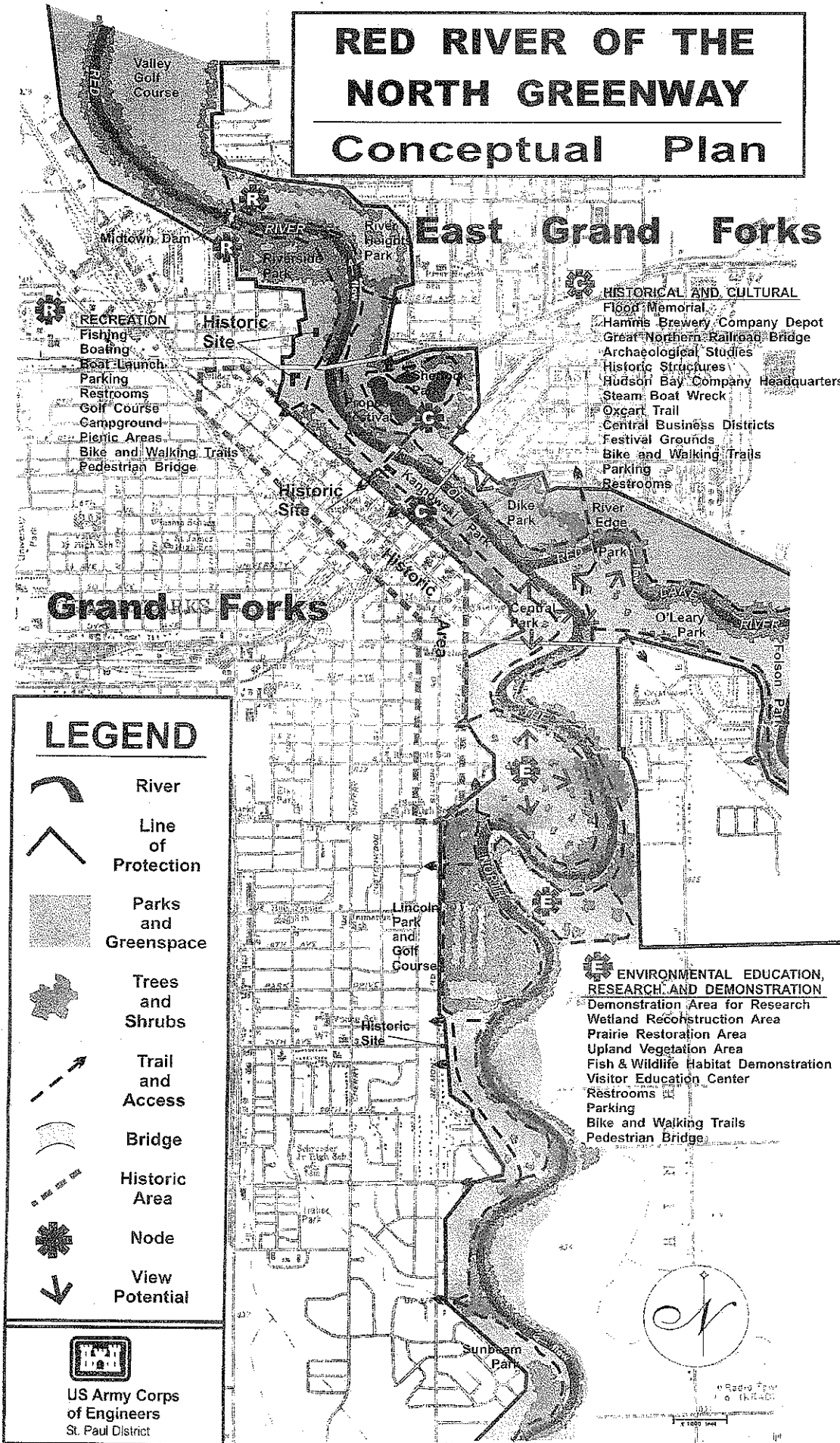

East Grand Forks

Grand Forks

- RECREATION**
- Fishing
 - Boating
 - Boat Launch
 - Parking
 - Restrooms
 - Golf Course
 - Campground
 - Picnic Areas
 - Bike and Walking Trails
 - Pedestrian Bridge

- HISTORICAL AND CULTURAL**
- Flood Memorial
 - Hammis Brewery Company Depot
 - Great Northern Railroad Bridge
 - Archaeological Studies
 - Historic Structures
 - Hudson Bay Company Headquarters
 - Steam Boat Wreck
 - Oxcart Trail
 - Central Business Districts
 - Festival Grounds
 - Bike and Walking Trails
 - Parking
 - Restrooms

LEGEND

- River
- Line of Protection
- Parks and Greenspace
- Trees and Shrubs
- Trail and Access
- Bridge
- Historic Area
- Node
- View Potential

- ENVIRONMENTAL EDUCATION, RESEARCH, AND DEMONSTRATION**
- Demonstration Area for Research
 - Wetland Reconstruction Area
 - Prairie Restoration Area
 - Upland Vegetation Area
 - Fish & Wildlife Habitat Demonstration
 - Visitor Education Center
 - Restrooms
 - Parking
 - Bike and Walking Trails
 - Pedestrian Bridge

US Army Corps of Engineers
St. Paul District

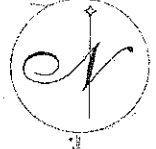

Scale 1" = 1000'

The Greenway

East Grand Forks Concept Plan • East Grand Forks, MN

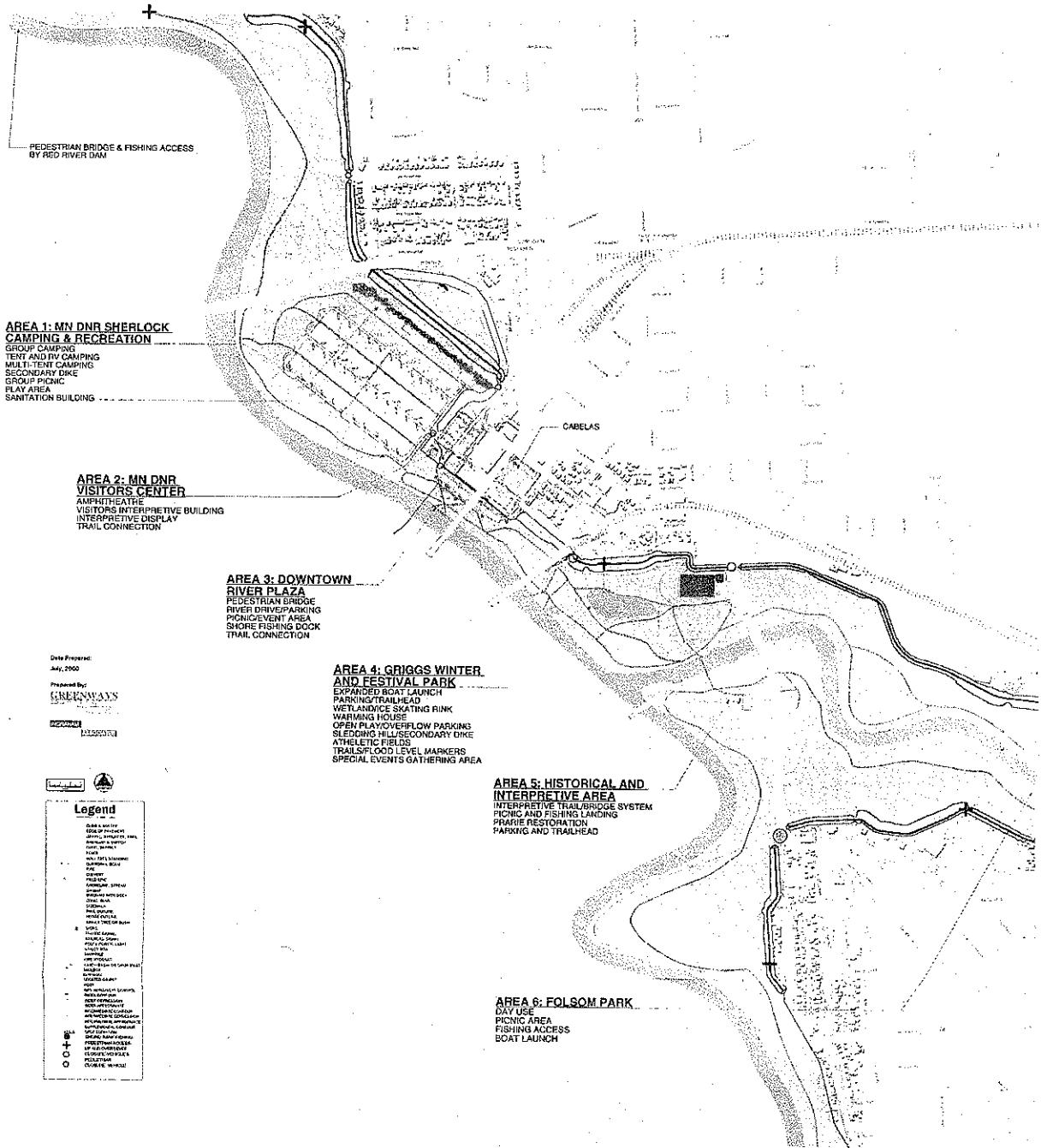

AREA 1: MN DNR SHERLOCK CAMPING & RECREATION
 GROUP CAMPING
 TENT AND RV CAMPING
 MULTI-USE CAMPING
 SECONDARY DIKE
 GROUP PICNIC
 PLAY AREA
 SANITATION BUILDING

AREA 2: MN DNR VISITORS CENTER
 AMPHITHEATRE
 VISITORS INTERPRETIVE BUILDING
 INTERPRETIVE DISPLAY
 TRAIL CONNECTION

AREA 3: DOWNTOWN RIVER PLAZA
 PEDESTRIAN BRIDGE
 RIVER DRIVE/PARKING
 PICNIC/EVENT AREA
 SHORE FISHING DOCK
 TRAIL CONNECTION

AREA 4: GRIGGS WINTER AND FESTIVAL PARK
 EXPANDED BOAT LAUNCH
 PARKING/TRAILHEAD
 WETLANDS/SKATING RINK
 WARMING HOUSE
 OPEN PLAY/OVERFLOW PARKING
 SLEDGING HILL/SECONDARY DIKE
 ATHLETIC FIELDS
 TRAILS/FLOOD LEVEL MARKERS
 SPECIAL EVENTS GATHERING AREA

AREA 5: HISTORICAL AND INTERPRETIVE AREA
 INTERPRETIVE TRAIL/BRIDGE SYSTEM
 PICNIC AND FISHING LANDING
 PRAIRIE RESTORATION
 PARKING AND TRAILHEAD

AREA 6: FOLSOM PARK
 DAY USE
 PICNIC AREA
 FISHING ACCESS
 BOAT LAUNCH

Date Prepared:
 July, 2000
 Prepared By:
GREENWAYS
 CONSULTANTS

Legend

Blue line	Blue Line
Green line	Green Line
Yellow line	Yellow Line
Red line	Red Line
Black line	Black Line
Grey line	Grey Line
Blue area	Blue Area
Green area	Green Area
Yellow area	Yellow Area
Red area	Red Area
Black area	Black Area
Grey area	Grey Area
Blue circle	Blue Circle
Green circle	Green Circle
Yellow circle	Yellow Circle
Red circle	Red Circle
Black circle	Black Circle
Grey circle	Grey Circle
Blue square	Blue Square
Green square	Green Square
Yellow square	Yellow Square
Red square	Red Square
Black square	Black Square
Grey square	Grey Square
Blue triangle	Blue Triangle
Green triangle	Green Triangle
Yellow triangle	Yellow Triangle
Red triangle	Red Triangle
Black triangle	Black Triangle
Grey triangle	Grey Triangle
Blue diamond	Blue Diamond
Green diamond	Green Diamond
Yellow diamond	Yellow Diamond
Red diamond	Red Diamond
Black diamond	Black Diamond
Grey diamond	Grey Diamond
Blue star	Blue Star
Green star	Green Star
Yellow star	Yellow Star
Red star	Red Star
Black star	Black Star
Grey star	Grey Star
Blue cross	Blue Cross
Green cross	Green Cross
Yellow cross	Yellow Cross
Red cross	Red Cross
Black cross	Black Cross
Grey cross	Grey Cross
Blue circle with cross	Blue Circle with Cross
Green circle with cross	Green Circle with Cross
Yellow circle with cross	Yellow Circle with Cross
Red circle with cross	Red Circle with Cross
Black circle with cross	Black Circle with Cross
Grey circle with cross	Grey Circle with Cross
Blue square with cross	Blue Square with Cross
Green square with cross	Green Square with Cross
Yellow square with cross	Yellow Square with Cross
Red square with cross	Red Square with Cross
Black square with cross	Black Square with Cross
Grey square with cross	Grey Square with Cross
Blue triangle with cross	Blue Triangle with Cross
Green triangle with cross	Green Triangle with Cross
Yellow triangle with cross	Yellow Triangle with Cross
Red triangle with cross	Red Triangle with Cross
Black triangle with cross	Black Triangle with Cross
Grey triangle with cross	Grey Triangle with Cross
Blue diamond with cross	Blue Diamond with Cross
Green diamond with cross	Green Diamond with Cross
Yellow diamond with cross	Yellow Diamond with Cross
Red diamond with cross	Red Diamond with Cross
Black diamond with cross	Black Diamond with Cross
Grey diamond with cross	Grey Diamond with Cross
Blue star with cross	Blue Star with Cross
Green star with cross	Green Star with Cross
Yellow star with cross	Yellow Star with Cross
Red star with cross	Red Star with Cross
Black star with cross	Black Star with Cross
Grey star with cross	Grey Star with Cross
Blue cross with circle	Blue Cross with Circle
Green cross with circle	Green Cross with Circle
Yellow cross with circle	Yellow Cross with Circle
Red cross with circle	Red Cross with Circle
Black cross with circle	Black Cross with Circle
Grey cross with circle	Grey Cross with Circle
Blue square with circle	Blue Square with Circle
Green square with circle	Green Square with Circle
Yellow square with circle	Yellow Square with Circle
Red square with circle	Red Square with Circle
Black square with circle	Black Square with Circle
Grey square with circle	Grey Square with Circle
Blue triangle with circle	Blue Triangle with Circle
Green triangle with circle	Green Triangle with Circle
Yellow triangle with circle	Yellow Triangle with Circle
Red triangle with circle	Red Triangle with Circle
Black triangle with circle	Black Triangle with Circle
Grey triangle with circle	Grey Triangle with Circle
Blue diamond with circle	Blue Diamond with Circle
Green diamond with circle	Green Diamond with Circle
Yellow diamond with circle	Yellow Diamond with Circle
Red diamond with circle	Red Diamond with Circle
Black diamond with circle	Black Diamond with Circle
Grey diamond with circle	Grey Diamond with Circle
Blue star with circle	Blue Star with Circle
Green star with circle	Green Star with Circle
Yellow star with circle	Yellow Star with Circle
Red star with circle	Red Star with Circle
Black star with circle	Black Star with Circle
Grey star with circle	Grey Star with Circle

The Greenway

East Grand Forks Concept Plan • East Grand Forks, MN

